

APPLICATION

The pressure reducing valve type UZRR6... is used for reducing pressure in hydraulic systems.

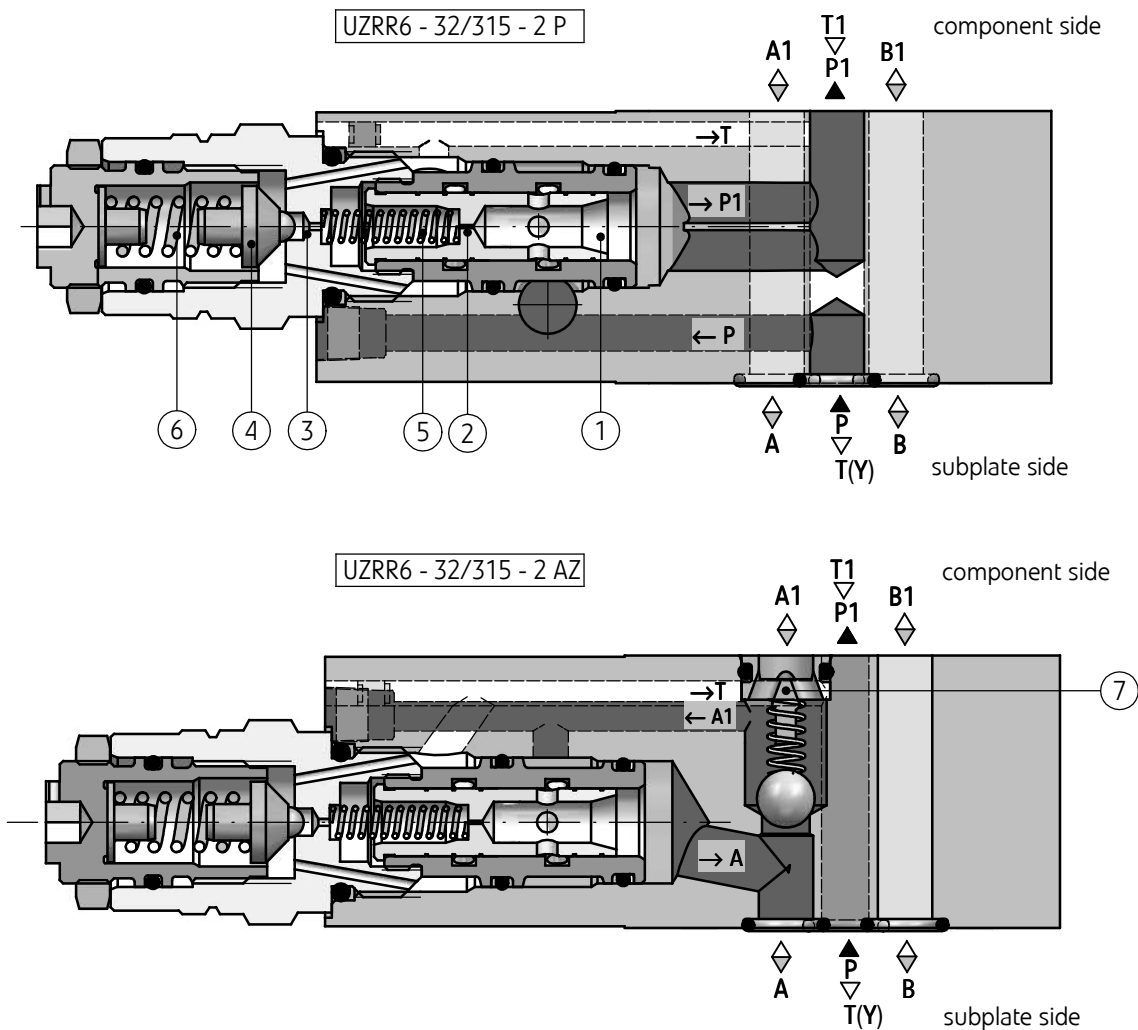

DESCRIPTION OF OPERATION



The valve consists of pilot valve and main valve. The reduced pressure acts on the lower face of main spool (1), and through nozzle (2) also on the upper face and through nozzle (3) on pilot valve poppet (4). In rest position the pressure on both sides of the main spool (1) is identical. Spring (5) maintains the spool in initial (open) position. Lines P and P1 (A1 to A, B1 to B) are interconnected. When the pressure attains the value

determined by the tension of spring (6), the pilot valve (4) opens and oil flows through nozzle (2). A pressure drop is created across the nozzle, which acts on the upper and lower faces of spool (1) and moves it causing throttling of flow from P to P1 (A1 to A, B1 to B). Unrestricted flow in opposite direction from A to A1 (B to B1) is effected through check valve (7) - design with check valve UZRR6...AZ; (UZRR6...BZ).

TECHNICAL DATA

Hydraulic fluid	mineral oil	
Required filtration	up to 16 μm	
Recommended filtration	up to 10 μm	
Nominal fluid viscosity	37 mm^2/s at temperature 55 °C	
Viscosity range	2,8 up to 380 mm^2/s	
Fluid temperature range (in a tank)	recommended	40°C up to 55°C
	max	-20°C up to +70°C
Ambient temperature range	-20°C up to +70°C	
Maximum operating pressure	31,5 MPa	
Maximum set pressure	31,5 MPa	
Pressure at inlet connection	up to 31,5 MPa	
Pressure at outlet connection	0,3 - 31,5 MPa	
Settable pressure range	5 MPa; 10 MPa; 20 MPa; 31,5 MPa	
Maximum flow	50 dm^3/min	
Weight	1,7 kg	

SCHEMES

Hydraulic schemes of valves type UZRR6...

version UZRR6...P...

component side

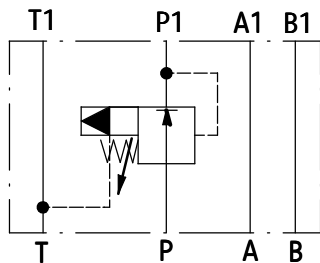

subplate side

version UZRR6...A...

component side

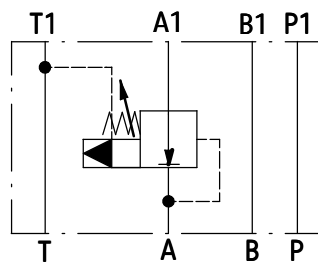

subplate side

version UZRR6...B...

component side

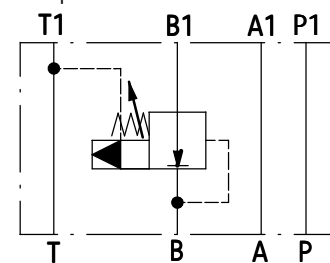

subplate side

version UZRR6...AZ...

component side

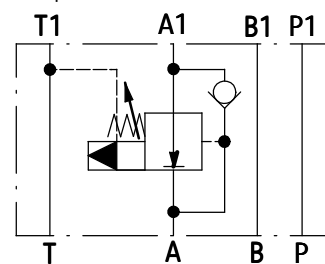

subplate side

version UZRR6...BZ...

component side

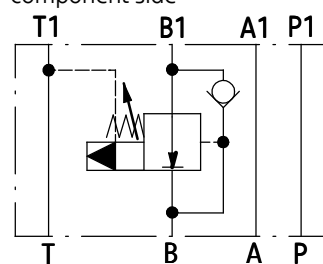

subplate side

OVERALL AND CONNECTION DIMENSIONS

version UZRR6...P...

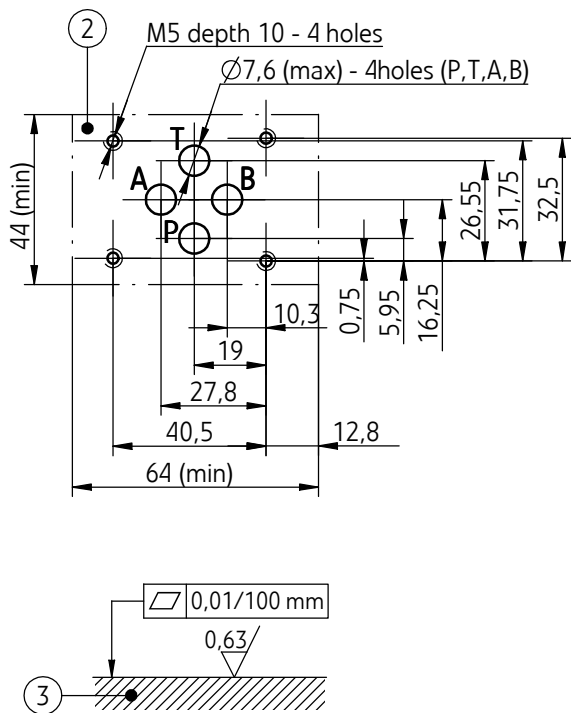
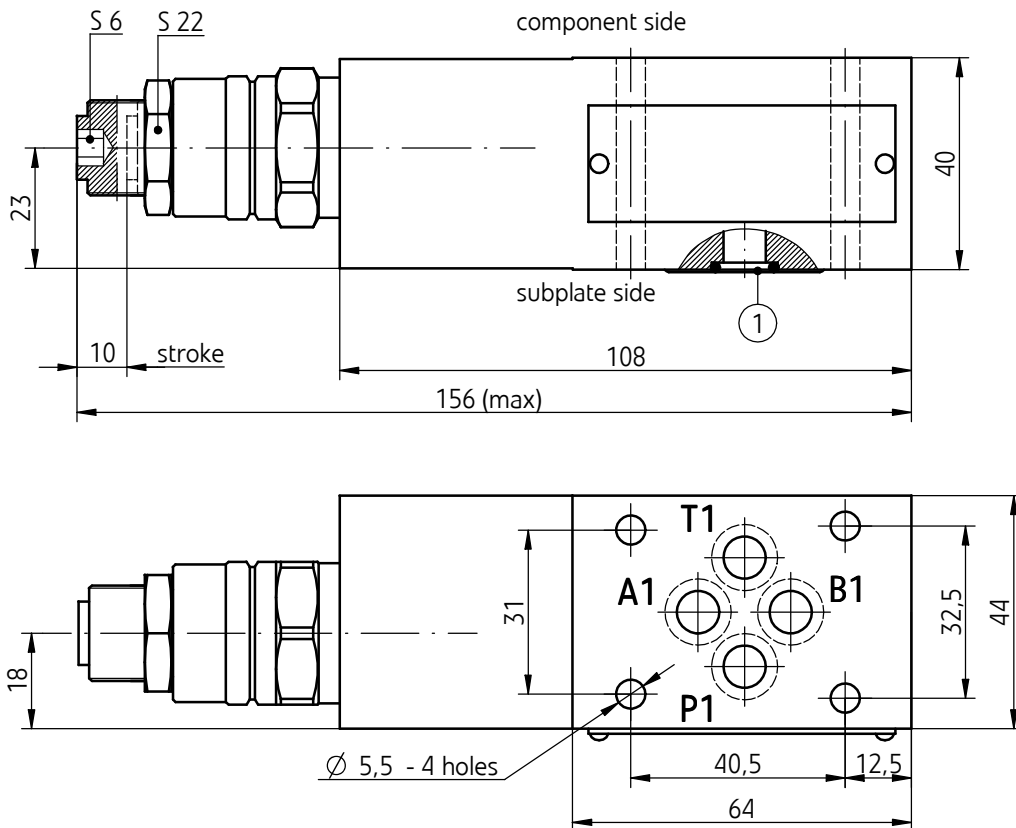

- 1 - Seal **o-ring 9,25 x 1,78** - 4 pcs/kit (P, T, A, B)
 - 2 - Mounting holes configuration of a subplate in accordance with the standards listed below:
 - **CETOP RP 121H** - symbol **CETOP 4.2-4-03** (nominal size **CETOP 03**)
 - **ISO 4401** - symbol **ISO 4401-03-02-0-94** fixing screws **M5 x L*** - 4 pcs/kit in accordance with **PN - EN ISO 4762** tightening torque **Md = 9 Nm**
 - 3 - Required surface finish of a subplate
- NOTE:**
 (*) - Required length of the screws L is related to type and the number of hydraulic components sandwich fitted

OVERALL AND CONNECTION DIMENSIONS

versions: UZRR6...A...; UZRR6...AZ...

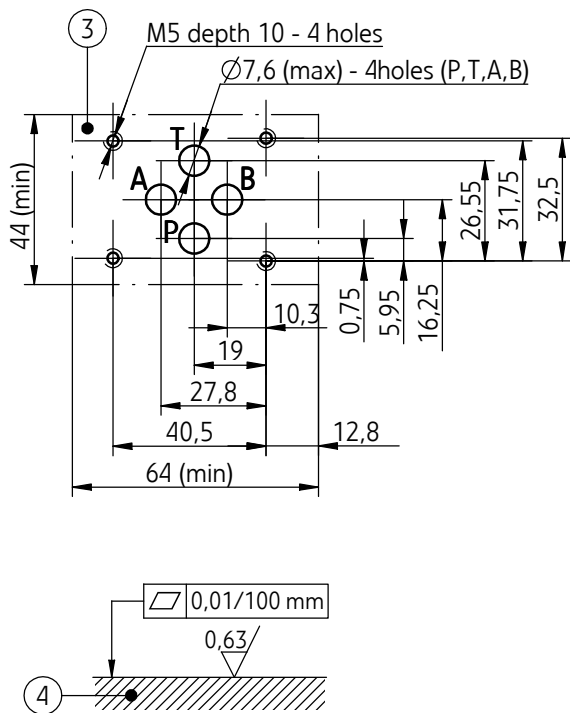
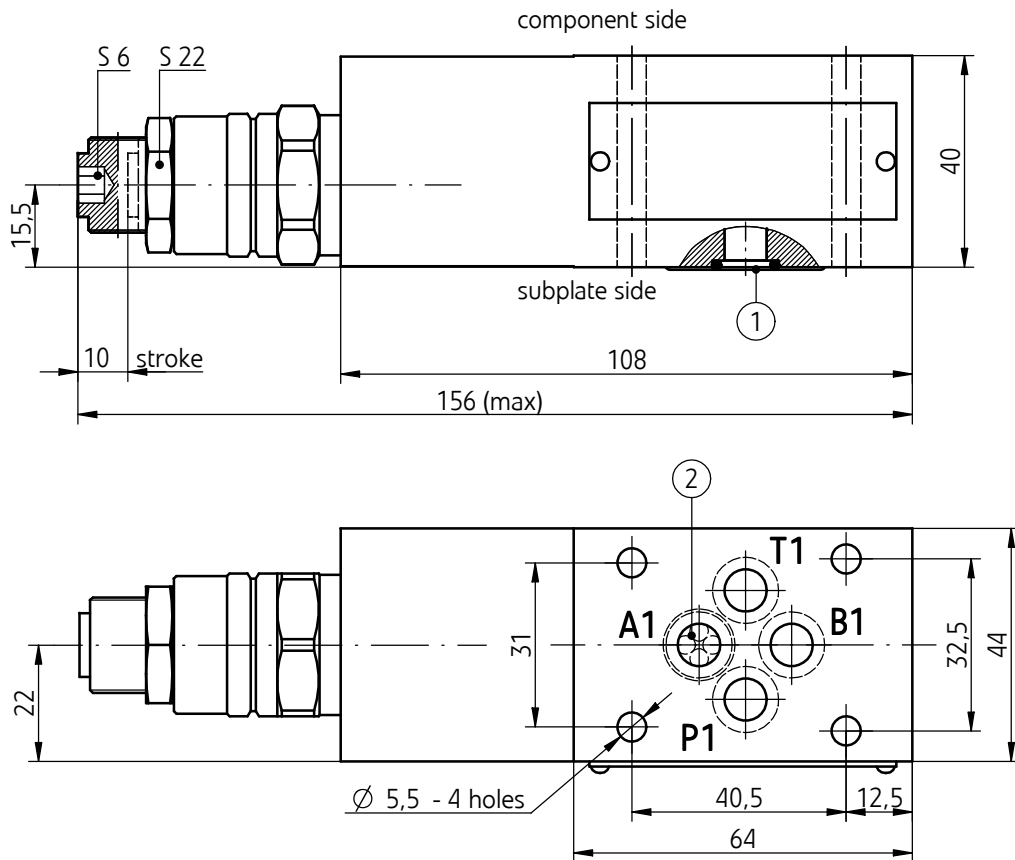

- 1 - Seal **o-ring 9,25 x 1,78** - 4 pcs/kit (P, T, A, B)
 - 2 - Check valve in line **A - A1** - only for version UZRR6...AZ...
 - 3 - Mounting holes configuration of a subplate in accordance with the standards listed below:
 - **CETOP RP 121H** - symbol **CETOP 4.2-4-03** (nominal size **CETOP 03**)
 - **ISO 4401** - symbol **ISO 4401-03-02-0-94** fixing screws **M5 x L*** - 4 pcs/kit in accordance with **PN - EN ISO 4762** tightening torque **Md = 9 Nm**
 - 4 - Required surface finish of a subplate
- NOTE:**
 (*) - Required length of the screws **L** is related to type and the number of hydraulic components sandwich fitted

OVERALL AND CONNECTION DIMENSIONS

versions: UZRR6...B...; UZRR6...BZ...

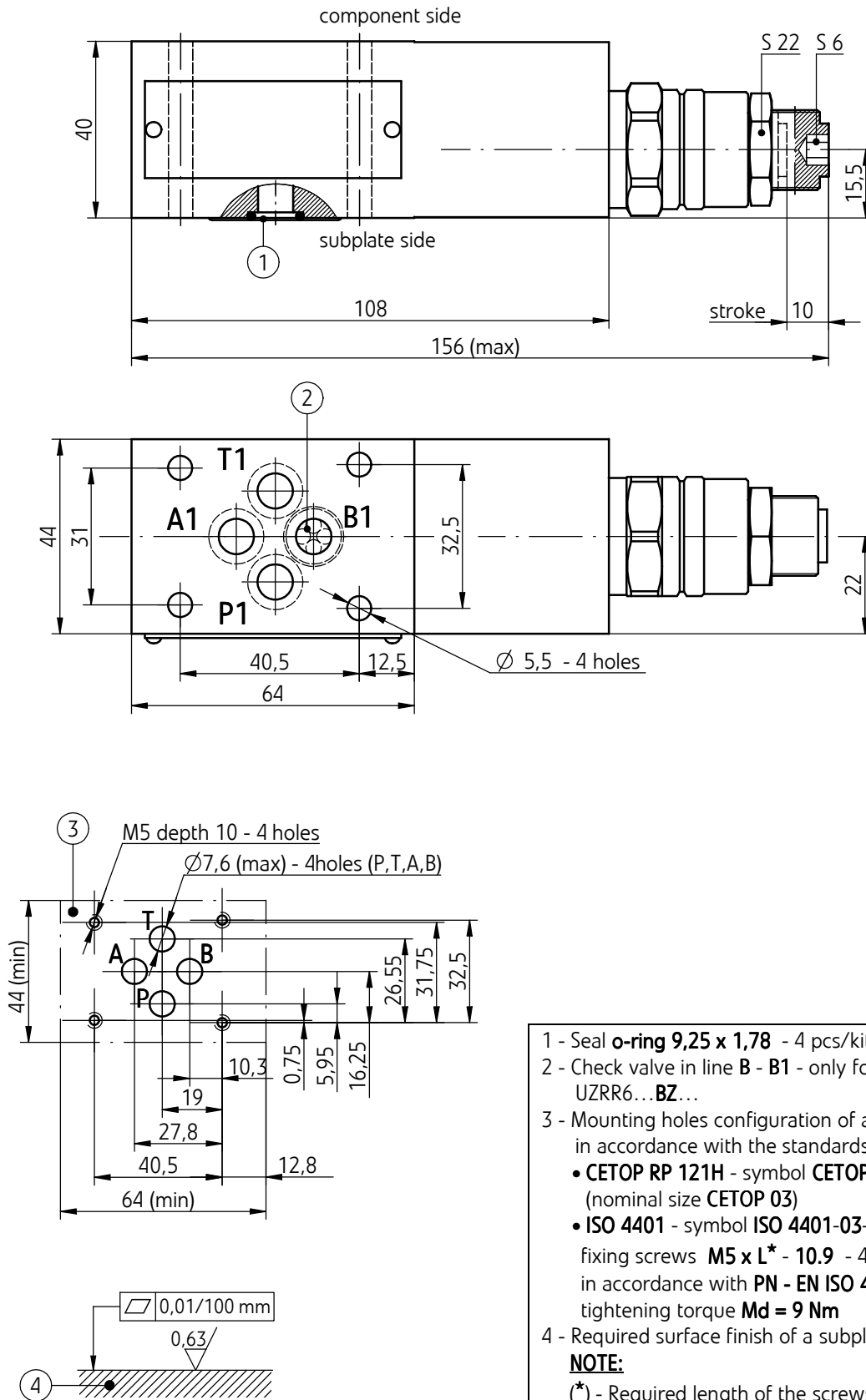

- 1 - Seal **o-ring 9,25 x 1,78** - 4 pcs/kit (P, T, A, B)
- 2 - Check valve in line **B - B1** - only for version UZRR6...BZ...
- 3 - Mounting holes configuration of a subplate in accordance with the standards listed below:
 - **CETOP RP 121H** - symbol **CETOP 4.2-4-03** (nominal size **CETOP 03**)
 - **ISO 4401** - symbol **ISO 4401-03-02-0-94** fixing screws **M5 x L*** - 4 pcs/kit in accordance with **PN - EN ISO 4762** tightening torque **Md = 9 Nm**
- 4 - Required surface finish of a subplate
NOTE:
 (*) - Required length of the screws **L** is related to type and the number of hydraulic components sandwich fitted

PERFORMANCE CURVES

measured at viscosity $\nu = 41 \text{ mm}^2/\text{s}$ and temperature $t = 50^\circ\text{C}$

Characteristic curves of pressure reduction

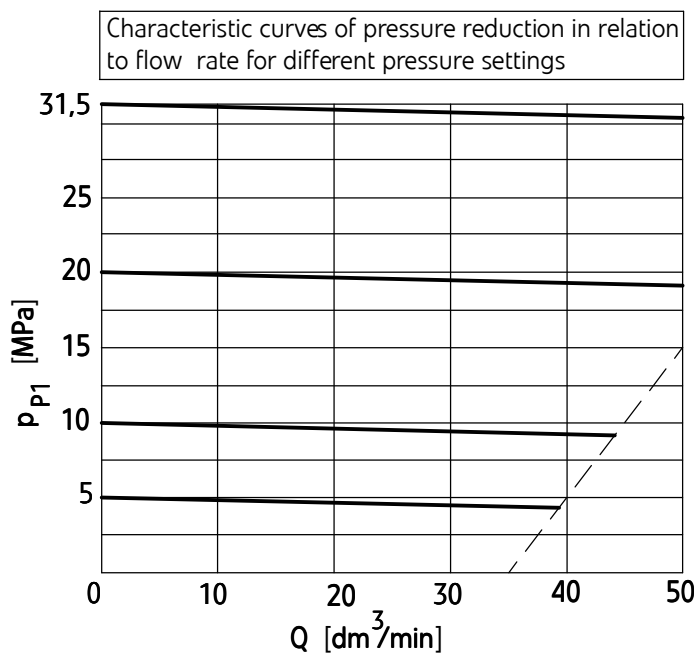

Characteristic curves of flow resistance

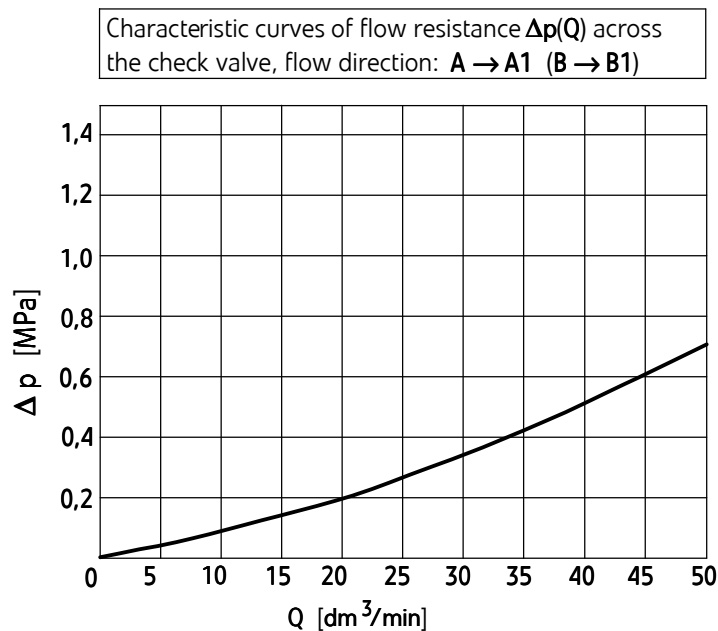

HOW TO ORDER

UZRR	6	-	/	-				*
------	---	---	---	---	--	--	--	---

Nominal size (NS)
NS6 = 6

Series number
 (30-39) - connection and installation dimensions unchanged = 3X
series 32 = 32

Settable pressure range
 up to 5 MPa = 50
up to 10 MPa = 100
 up to 20 MPa = 200
up to 31,5 MPa = 315

Adjustment element
set screw with internal hexagon = 2

Connection (according to schemes on page 2)
Reduction in line P = P
 Reduction in line A = A
 Reduction in line B = B
 Reduction in line A + check valve = AZ
 Reduction in line B + check valve = BZ

Sealing
NBR (for fluids on mineral oil base) = no code
 FKM (for fluids on phosphate ester base) = V

Further requirements in dear text
 (to be agreed with the manufacturer)

NOTES:

The pressure reducing valve should be ordered according to the above coding.

The symbols in bold are the preferred versions available in short delivery time.

Coding example: UZRR6 - 32/315 - 2 P

SUBPLATES AND FIXING SCREWS

Subplates must be ordered according to catalogue sheet **WK 496 480**. Subplate symbols:

G 341/01 - threaded connections G 1/4

G 342/01 - threaded connections **G 3/8**

G 502/01 - threaded connections G 1/2

G 341/02 - threaded connections M14 x 1,5

G 342/02 - threaded connections M16 x 1,5

Subplates and screws fixing the pressure reducing valve **M5 x L*** - 10,9 - 4 pcs/kit in accordance with **PN - EN ISO 4762** must be ordered separately.

Tightening torque **Md = 9 Nm**

NOTES:

(*) - Required length of the screws L is related to type and the number of hydraulic components sandwich fitted.

The subplate symbol in bold is the preferred version available in short delivery time.

PONAR Wadowice S.A.
ul. Wojska Polskiego 29
34-100 Wadowice
tel. +48 33 488 21 00
fax. +48 33 488 21 03
www.ponar-wadowice.pl

